



Fiddler's Rag

Vol. 41, Number 11
Celebrating 40 years

Santa Clara Valley Fiddlers Association
www.scvfa.org -or- www.fiddlers.org

November 2013
Next Jam: Nov. 3



President's Note

There was a lot happening at our October 6 jam. It was a big success thanks to lots of people. Trustee George Bradshaw, Janet Johnston and I brought the storage locker supplies.

Charlotte Prater, Janet Johnston and Donna Ellis staffed the front desk. Our Beginner Circle was started by Jean Avram and continued by Xiaoli Chen. Luke Abbott led a very successful KidFiddle workshop. Mary Kennedy, our youth activities coordinator, also deserves our thanks. Sam Morocco stepped up to the mic to do an outstanding job as MC. He entertained us with a few corny jokes and introduced everyone who played on stage. Great job!

Rhythm Roundup, our Featured Performer, entertained an appreciative audience with some bluegrass, western swing, and swing jazz. The band includes Chip Curry on mandolin, banjo, and fiddle; Michael Schwartz on guitar; Sam Morocco on bass; and me on fiddle.

Helping with the important cleanup task was Rudy Posch, Mike Bell, George Bradshaw and myself.

12th Youth Fiddle Contest

Our 12th Youth Fiddle Contest will be on November 3 thanks to Pete Showman who is willing to be the Chairman once again. If you know someone 17 or under who plays fiddle, let them know about the cash prizes. Let Pete know if you can help him out.

Help Promote the SCVFA

Who wants some marketing experience? We need someone to get the word out about our jams and to inquire about performing in the community at senior centers and music events. The modest fee we charge to perform is an important source of income.

Holiday Potluck on December 1

This year's holiday potluck dinner on December 1 is being organized by Cheri Palasek and Lee Clarke. If you can help them out, please let me know.

- Richard Brooks

Barbara Ann Barnett (1942-2013) *Richard Brooks*

On October 10, 2013, the music community lost a great musician and friend, to brain cancer. Barbara Ann Barnett, accordionist, singer and pianist, was 70. She had been an SCVFA member since 1985.



She was a versatile musician who played western swing, bluegrass, and traditional jazz (Dixieland) styles. You can hear her music on YouTube and on several recordings: **Mandolin Squeeze** "Through the Years" with David Rengers (mandolin) (tape, 1988); **Lone Prairie** "Desert Flower" (CD, 1996); **Sagebrush Swing** "Western at Heart – cowgirl jazz with pizzazz," duets with Audrey McLaughlin (CD, 2000).

Sam Morocco and I accompanied Sagebrush Swing (Barbara Ann and Audrey) on the SCVFA stage many times. Barbara Ann liked to "squeeze out tunes," as she put it. She knew musicians everywhere. In February

(continued on page 3)

2013 Youth Fiddle Contest

Attention Young Fiddlers: the 12th Annual SCVFA Youth Fiddle Contest will be held on November 3, 2013. Page 3 has more information. For full details go to www.fiddlers.org/contest and download the flyer, rules and entry form.

Update: As of 10/23 we are less than half full, and are especially short on Div. 3 entries (17 and under). If you'd like to give it a try please sign up, in advance if you can, or at the contest (1-1:30).

In This Issue:

Page

President's Message	1
Barbara Ann Barnett remembered	1, 3
SCVFA Happenings – Youth Fiddle Contest, December potluck, Prusch Farm payout ..	3
Photos	4
Tunes: Miller's Reel (<i>two versions</i>)	5

The Fiddler's Rag is published monthly by the Santa Clara Valley Fiddlers Association and is provided to members of the Association. The Santa Clara Valley Fiddlers Association (SCVFA), founded in 1973 in San Jose, California, is a nonprofit, volunteer-operated organization dedicated to the preservation, teaching, and enjoyment of traditional music. The first membership in a household includes the Fiddler's Rag; additional members sharing the newsletter are steeply discounted. To join, sign up at the jam or see www.fiddlers.org/join.

Officers and Chairs

President-Trustee Richard J. Brooks
 Vice President OPEN
 Recording Secretary Dinah Showman
 Treasurer Janet Johnston
 Membership Secretary Pete Showman
 Newsletter Editor OPEN (*Pete Showman, acting*)
 Newsletter Publisher Charlotte Prater
 Performances Contact Dave Williams
 Publicity OPEN
 Webmaster Pete Showman
 Youth Activity Coordinator Mary Kennedy
 Youth Fiddle Contest Chair, 2013 Pete Showman

Trustees

Seat 1: Pete Showman Seat 2: Barbara Rosner
 Seat 3: George Bradshaw Seat 4: Charlotte Prater
 Seat 5: Dave Williams Seat 6: Tom Clausen

To Contact the SCVFA:

Mail: P.O. Box 2666, Cupertino, CA 95015-2666
 Email: president at fiddlers.org Phone: (650) 328-3939

Newsletter Submissions & Comments:

Email: newsletter at fiddlers.org

Website: www.scvfa.org or www.fiddlers.org

Copyright 2012, Santa Clara Valley Fiddlers Association

From Marin to Monterey, Tracy to Tiburon...
...we're in the heart of bluegrass country



THE NORTHERN CALIFORNIA BLUEGRASS SOCIETY
www.ncbs.us

Since 1982 the Northern California Bluegrass Society has promoted bluegrass and old time music in the San Francisco Bay and Monterey Bay areas. This highly active club has nurtured the development of bands and venues. The NCBS hosts the Good Old Fashioned Bluegrass Festival each August, an event that solely features California bands. We sponsor festivals, concerts and jams all over the area. Members receive the Bluegrass By the Bay magazine each quarter. Please join us!

**YOU can become an SCVFA
Trustee. See page 3.**



Barbara Rosner photo

Rhythm Roundup was the Featured Performer at the October jam.
 L-R: **Chip Curry, Richard Brooks, Sam Morocco and Michael Schwartz.**

SCVFA Happenings

Calling All Young Fiddlers! Sign Up for our 12th annual SCVFA Youth Fiddle Contest November 3, 2013

Young fiddlers, parents, teachers —
time to sign up for the contest
and get a couple of tunes ready!
As of October 23 we have lots
of openings. Don't be shy!
Sign up today!

Everyone — come cheer
on these young fiddlers!

Three age divisions:

8 and under, 11 and under, 17 and under.

- Cash prizes for 1st through 5th in each division.
- Custom-made fiddle trophies for first place.
- Participant ribbons for all.

Pre-registration is strongly encouraged.

Full details and the entry form are on our
website: www.fiddlers.org/contest. Questions?
Call Pete Showman: (408) 255-0297.



Join us for the SCVFA Holiday Potluck Sunday, December 1

- Jamming and stage performances from 1-3 PM
- Potluck Dinner starts at 3 PM

Please bring lots of side dishes and a few desserts.
The SCVFA will provide turkey, ham, beverages,
eating utensils and decorations.

Bring one dish to feed four times as many as are in
your group. So if you come alone, bring enough
for four people. If you come as a couple, bring
enough for 8. Please bring your own serving
utensils and tape your name on your serving dishes
so we know who they belong to.

Can't bring a dish? Come anyway, and buy a meal
ticket for just \$5.

Note: We do not have permission to use the kitchen
facilities (kitchen sinks or electrical
outlets). No food warmers or
electric utensils are permitted.

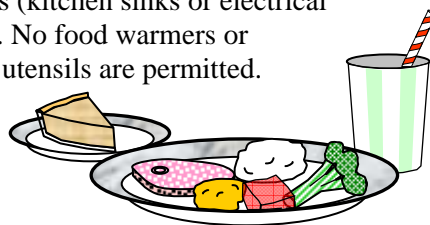

Barbara Ann Barnett *(continued from p.1)*

2012, she made a one year commitment to sing with
the Golden Gate Radio Orchestra.

On August 5, 2013, Barbara Ann emailed, "It is very
satisfying to go on feeling a sense of belonging to
groups I've belonged to for decades," referring to the
SCVFA and the South Bay Traditional Jazz Society.
A blog at babdesertflower.blogspot.com celebrates her
life and family.

Her last days were spent in Santa Cruz near her son
Beau. She emailed, "My spirits are quite strong and
my mood seems unshakable." We will miss her.

Beau Barnett and Audrey McLaughlin are planning a
celebration of Barbara Ann's life, next May or June.

See page 4 for some photos of Barbara Ann at
SCVFA.



Potluck Help Needed

Potluck co-chairs **Cheri Palasek** and **Lee Clarke** will
need help before and especially during the Holiday
Potluck at the December jam. If you can help out, please
contact one of them, or any board member.

Oct 5th Payout at Prusch Farm Park

On October 5th several SCVFA musicians were
welcomed to the stage at the annual Harvest Festival at
San Jose's Prusch Farm Park, and performed a variety of
tunes and songs. The musicians were **Jean Avram**,
George Bradshaw, **Richard Brooks**, **Warren
Campbell**, **Paul Clarke** (organizer), **Tom Mitchell**,
Sam Morocco, **Anne and Phil Pflager** and **Jim
Reynolds**. See the photo on page 4.

Become an SCVFA Trustee

We need one or more members to run in the February
trustee election, to fill a vacancy. If you're interested,
contact any board member by mid-November.

The six elected trustees, along with the president and
several officers, guide the SCVFA. We meet every other
month. It's a great way to help influence our direction,
and to give back to the association.

Barbara Ann Barnett at SCVFA



Barbara Ann with Janet Johnston (above, March 2008) and having fun with Steve Kirtley (center, June 2005).
Richard Brooks photos.



Barbara Ann "squeezes out some tunes" at the May 2005 jam.

Recent Events



Janet Reynolds photo

Performers at the Prusch Farm Park playout (L-R): George Bradshaw, Warren Campbell (behind George), Richard Brooks, Jim Reynolds, Tom Mitchell, Sam Morocco (behind Tom), Jean Avram, Paul Clarke and Phil Pflager. (Anne Pflager was also present, but not in the photo)



Todd Townsend and John Durbin entertain at the October 2013 jam.



Past President Fritz Buell dances with Lee Clarke at the October jam.

Richard Brooks photos

KAMIMOTO
STRING INSTRUMENTS

"Fiddles for Every Style..."

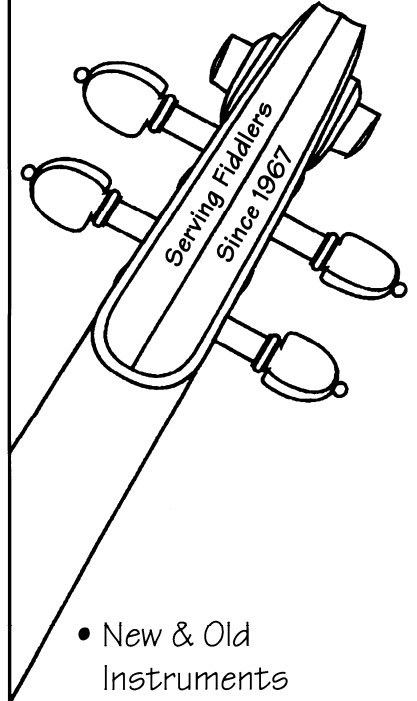

- New & Old Instruments
- Repairs & Restorations
- One-hour bow rehairing (by appt.)
- Rentals: Violin, Viola, Cello, Bass

Hours: Mon-Sat 10:00 - 5:30

[408] 298-8168
www.kamimotostrings.com

609 North Fourth Street
San Jose, CA 95112

[800] 892-3199

Fax: [408] 298-8198

Miller's Reel in A

♩ = 90-100

Traditional, Arr. Pete Showman

The score for Miller's Reel in A consists of four staves of music in the key of A major (two sharps). The first staff begins with a boxed 'A' and contains the first measure of the piece. The second staff continues the melody and includes a first ending (1) and a second ending (2), both leading to a triplet of eighth notes. The third staff begins with a boxed 'B' and continues the melody. The fourth staff continues the piece, also featuring a first ending (1) and a second ending (2) that concludes with a triplet of eighth notes.

Arr. and typeset in ABC by Pete Showman 5/07. A blend from various sources, more or less as I play it.
Rev 2: 10/17/2013

Miller's Reel in G

♩ = 90-100

(J.P. Fraley version)

Traditional; J.P. Fraley ver.
Arr. Pete Showman

The score for Miller's Reel in G is in the key of G major (one sharp). It consists of four staves of music. The first staff begins with a boxed 'A' and a treble clef with a sharp sign, followed by the first measure of the piece. The second staff continues the melody and includes a first ending (1) and a second ending (2), both leading to a G chord. The third staff begins with a boxed 'B' and continues the melody. The fourth staff continues the piece, also featuring a first ending (1) and a second ending (2) that concludes with a G chord and the instruction '(D.S. to repeat)'.

Transcribed and arr. by Pete Showman from J.P. and Annadeene Fraley's "Wild Rose of the Mountain" album (1974). The recording ends on the A part, and probably didn't use minor chords. Rev 1: 10/20/2013

Santa Clara Valley Fiddlers Association
P.O. Box 2666
Cupertino, CA 95015-2666

SCVFA Jam on the first Sunday of each month.
Location: Hoover Middle School, 1635 Park Ave.,
San Jose. The school is at the corner of Naglee and
Park. Cafeteria parking is on the Naglee side.

**Next Jam: Sunday Nov. 3, 1-5 pm
at Hoover Middle School
** Youth Fiddle Contest ****

**Damaged or Missing Issue? Call us,
or email to: newsletter at scvfa.org**

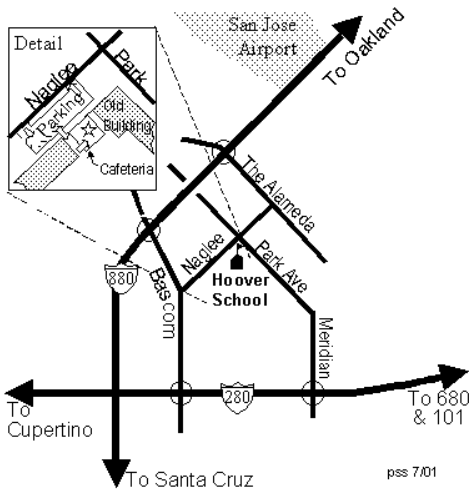

Richard Brooks photo

The young participants in the October KidFiddle workshop, L-R: Rebecca Jaworski, Khushi Parikh, Katherine Kline, Rachelle Lang, Matthew Newman, Lilly Haugaard, Elizabeth Kline. Back row: parents Alison and Bob Kline (left) worked on backup with KidFiddle coordinator Mary Kennedy (right), while instructor Luke Abbott taught the kids fiddling.