



Fiddler's Rag

Vol. 43, Number 11
Celebrating 42 years

Santa Clara Valley Fiddlers Association
www.scvfa.org or www.fiddlers.org

November 2015
Next Jam: Nov. 1

President's Note



Jeanne Sawyer and Anders Holtsberg put on a fantastic show demonstrating "Folk Music from Scandinavia." Their twin fiddle harmonies and duets were superb. I really enjoyed learning the history of some tunes and the

dances they are played for. Jeanne also delighted us with her 9 string Hardanger fiddle with its 5 sympathetic "understrings" running under the fingerboard.

The concert's success was also due to jam manager Susan Goodis and sound engineer Matt Mathis. They along with Tom Winchell brought our storage locker supplies to and from our jam. We need more help here.

Let's thank Wes Mitchell who led the Tune Builder Circle and Topher Health who led his Slow Jam. These are both favorite activities for many folks.

Hillbillies from Mars Concert Nov. 1 at 3:15 PM

The Hillbillies from Mars are local folks who will perform at 3:15 PM. They play their version of "Celtic and American traditional fiddle music with a healthy dose of their own "folk roots" of rock 'n' roll, swing, and Latin and African beats." There is no extra cost.



Two Trustee Openings Starting in February

Consider volunteering as a trustee to help determine our future activities and direction, and to ensure our continued success. There are two openings in February.

Holiday Potluck on December 6

December 6 is our annual holiday potluck. The board approved a \$5 door admission for everyone who brings food to share. Without food to share, we ask \$5 more.

- Richard Brooks

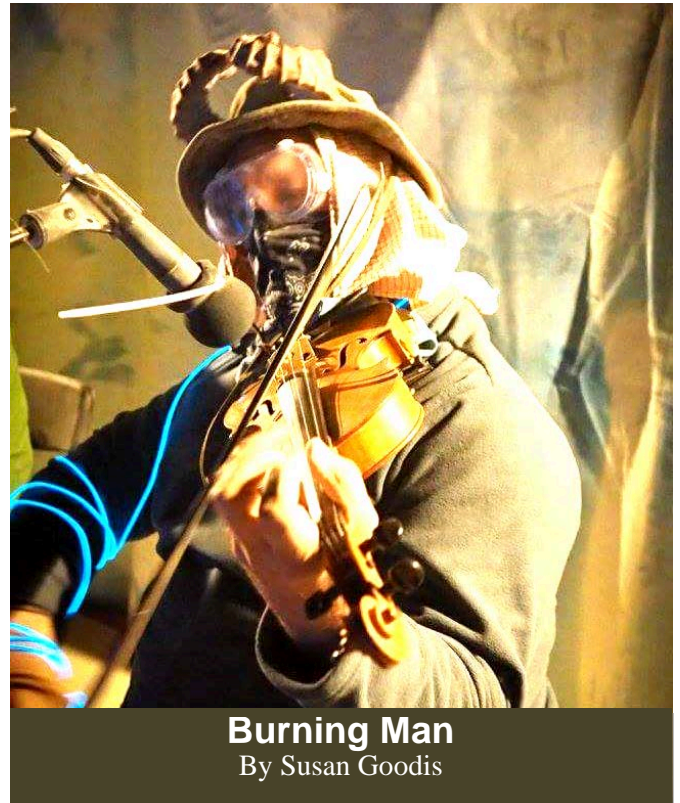

Burning Man
By Susan Goodis

Imagine a crop duster flying overhead to send a dusting of talcum powder onto the dance floor. Floors swept off in the evening reveal a spirited contra dance to live traditional music under the night sky lit only by solar lights and the stars. That's Black Rock City aka Burning Man, which comes to life for 8 days each year. This is an enormous art and music event with approximately 70,000 attendees.

(Continued on page 2)

In This Issue:

Page

President's Message	1
Burning Man by Susan Goodis.....	1,2,3
Slow Jam, Happenings, Lost and Found	3
Pictures from the October Jam (1/2)	4
Pictures from the October Jam (2/2)	5
Walker Creek Music Camp by Elan Alford	6
Tune: Over the Waterfall	7

The Fiddler's Rag is published monthly by the Santa Clara Valley Fiddlers Association and is provided to members of the Association. The Santa Clara Valley Fiddlers Association (SCVFA), founded in 1973 in San Jose, California, is a nonprofit, volunteer-operated organization dedicated to the preservation, teaching, and enjoyment of traditional music. The first membership in a household includes the Fiddler's Rag; additional members sharing the newsletter are steeply discounted. To join, sign up at the jam or see www.fiddlers.org/join.

Officers and Chairs

President-Trustee ...	Richard J. Brooks	Newsletter Publisher ..	Charlotte Prater
Vice President	OPEN	Performances Contact ..	Dave Williams
Recording Secretary	Dinah Showman	Publicity	OPEN
Treasurer	Janet Johnston	Webmaster	Pete Showman
Membership Secretary	Pete Showman	Youth Programs Chair	OPEN
News Editor	Patrice Tanti	Youth Fiddle Contest	Pete Showman

Trustees

Seat 1: Pete Showman	Seat 3: George Bradshaw	Seat 5: Dave Williams
Seat 2: Élan Alford	Seat 4: Charlotte Prater	Seat 6: Susan Goodis

To Contact the SCVFA:

Mail: P.O. Box 2666, Cupertino, CA 95015-2666
 Email to Richard Brooks: president [at] fiddlers.org

Newsletter Submissions & Comments:

Email: newsletter [at] fiddlers.org

Website: www.scvfa.org or www.fiddlers.org
 Copyright 2015, Santa Clara Valley Fiddlers Association

Everyone on the Playa (Burning Man) offers 'gifts'. My husband Matt Mathis and I offered the gift of dance and music by being major organizers for a Contra Dance and Music Camp in the Black Rock desert.

Celtic & Old-time jams as well as dances were held daily in the dusty environment. Musicians brought their second string instruments because of the harsh conditions. Dancers and musicians, out of necessity, wear face masks and goggles.

Experienced dancers share their love of dance by mentoring the newcomers. The camp band played for all the dances and jammed with other musicians every day.

(Continued on page 3)



Photo: Susan Goodis

KAMIMOTO
 STRING INSTRUMENTS

“Fiddles
 for
 Every Style...”

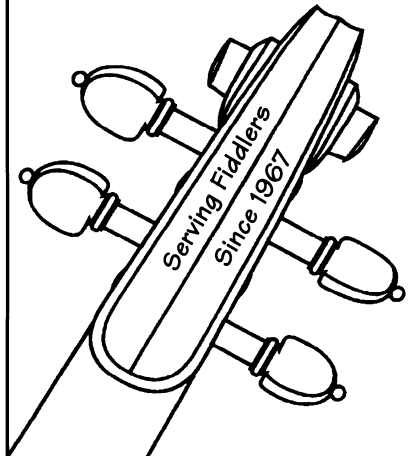

- New & Old Instruments
- Repairs & Restorations
- One-hour bow rehairing (by appt.)
- Rentals: Violin, Viola, Cello, Bass

Hours: Mon-Sat 10:00 - 5:30

[408] 298-8168
www.kamimotostrings.com

609 North Fourth Street
 San Jose, CA 95112

[800] 892-3199

Fax: [408] 298-8198

(Continued from page 2)

To keep track of time, days are given names such as Tutu Tuesday and White Wednesday. Tutu Tuesday is notable because most folks are wearing Tutus, while white, obviously, is worn on White Wednesday.

Dan Engle, fiddler from Yreka, Ca. played in the BMCC (Burning Man Contra Camp) band and held a Quebecois fiddle workshop on Tutu Tuesday.

Burning Man is an adventure and BMCC brings music and dance into the mix.

Maybe that will make it on your bucket list.

Happenings

SCVFA Slow Jam

Thank you all for participating in the slow jam. The slow jam is for beginners who want to participate in a slow-paced jam (60-90 BPM). To participate, you should be able to tune your instrument, play chords at a steady pace, and (optionally) work up melodies / leads.

The song list for November is:

- D Angeline The Baker
- D Arkansas Traveler
- A Cripple Creek (*key should be A, not G)
- G Girl I Left Behind Me
- G Hot Corn, Cold Corn
- D Jaybird (*new)
- D Liberty
- G Long Journey Home
- D Mississippi Sawyer (*new)
- G Mountain Dew
- A Old Joe Clark
- D Over The Waterfall (*new – Page 7 of this issue)
- A Red-Haired Boy
- D Soldier's Joy
- C Wildwood Flower
- A Will The Circle Be Unbroken
- G Worried Man Blues

Check here first for songs: www.scvfa.org/tunes

Share Your Photos

Share your photos and we will include your name if they are used in the Rag. Email them to newsletter editor Pat Tanti at [newsletter \[at\] fiddlers.org](mailto:newsletter[at]fiddlers.org).

Amazon Buyers

On the lower left side of our www.fiddlers.org website we have a link to Amazon. If you click on it to go to Amazon, we get a small commission if you make a purchase. It costs you nothing and it really helps us.



Join us for the SCVFA Holiday Potluck Sunday, Dec. 6th

- Jamming and stage performances from 1-3 PM
- Potluck Dinner starts at 3 PM

Please bring lots of side dishes and a few desserts. The SCVFA will provide turkey, ham, beverages, eating utensils and decorations.

Bring one dish to feed four times as many as are in your group. So if you come alone, bring enough for four people. If you come as a couple, bring enough for 8. Please bring your own serving utensils and tape your name on your serving dishes so we know who they belong to.

Can't bring a dish? Come anyway, and buy a meal for just \$5.

Note: We do not have permission to use the kitchen facilities (kitchen sinks or electrical outlets). No food warmers or electric utensils are permitted.

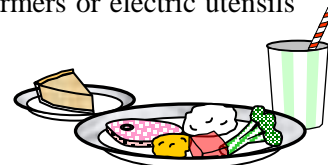

Potluck Help Needed

Potluck co-chairs **Cheri Palasek** and **Lee Clarke** will need help before and especially during the holiday potluck at the December jam. If you can help out, please contact one of them, or any board member.

Silicon Valley House Concerts Mountain View

- **YES M'am** on Saturday Nov. 7th 8 PM
 - **Megan Lynch Chowning** Afternoon Fiddle workshop and evening concert on **Dec. 5th** 8 PM
- Please email for a reservation, location and directions at [silicon-valley-house-concerts+managers \[at\] googlegroups.com](mailto:silicon-valley-house-concerts+managers[at]googlegroups.com)

Lost and Found

Left at the October jam: a green rectangular fiddle-case "blanket". Inquire at the back desk at the jam, or email Pete Showman at [membership \[at\] fiddlers.org](mailto:membership[at]fiddlers.org).

Photos from the October 2015 Jam



Soundman **Matt Mathis** standing at the mixer controls
(Photo: Richard Brooks)



Jeanne Sawyer and Anders Holtsberg proud of their performance
(Photo: Richard Brooks)



Mike Bell (giving the signal to end), **Clark Akatiff**, **Dave Williams**, **Robin Fish**, **Jerry Friedman**
(Photo: Richard Brooks)

Photos from the October 2015 Jam



(Photos above: Patrice Tanti)



Sam Morocco, Jean Avram, John Sellers, Norio Kawato
(Photo: Richard Brooks)

A Dispatch from the Fall 2015 Walker Creek Music Camp

By Elan Alford

Live from the front lines of Americana music in northern California: October 8-11, 2015 marks the fall session of Walker Creek Music Camp in Marin County. The camp is held at Walker Creek Ranch, which is primarily an outdoor education facility for Marin County fifth and sixth grade students. However when classes are not being provided the camp hosts groups for conferences, weddings, and even music camps.

Santa Clara Valley Fiddlers Association jammers were well represented at the camp this year. Two banjo players from Santa Cruz, Mark Hopkins and Craig Mitchell, attended the old time banjo class taught by Adam Hurt. The old-time fiddle class was taught by Earl White. Adrienne Davis, his wife and band mate, was the old time fiddle TA. At camp she was playing fiddle in class. Most of us are used to seeing Earl on the fiddle and Adrienne on guitar in the Earl White Band but Adrienne is multitalented and a budding fiddler too. On the first day of camp we learned Lost Creek from Earl. It is a two key tune with the A part in G and the B part in D. Santa Clara Valley Fiddle Association jammers who attended the

old-time fiddle class are: Elan Alford, Enid Bennion, John Alsop, Liz Herzfeld, Patti Bossert, Susan Goodis, Wayne Grabowski, and Wes Mitchell.

Earl is a talented fiddler who is self-taught. In class we discussed the all-important topic of bowing. To get Earl's sound, make circles with the bow.

A fantastic set of dance tunes was a feast for the ears and feet at the square dance. The Earl White Band (Earl, Adrienne, and Martha Hawthorne) along with Adam Hurt on banjo filled the dance barn with music. I danced with several SCVFA jammers. The barn floor was full all night with swirling bodies.

Walker Creek Music Camp is a great local resource that provides wonderful opportunities for SCVFA jammers. Classes are provided in the morning and electives are done in the afternoon. There are classes in old time and bluegrass styles. Whether you are looking for classes in singing, guitar, mandolin, bass, fiddle, banjo, or dobro, there are so many good choices. Come on out to camp sometime if you get the chance! It is offered every year in April and October.

Over and out from Marin County. I'll see you all in November!



Foreground kneeling: John Alsop, Enid Bennion, background standing: Earl White, Adrienne Davis, Wayne Grabowski, Liz Herzfeld, Wes Mitchell, Susan Goodis, Elan Alford, Patti Bossert
(Photo: David Pokorney)

D major

♩ = 90

Over the Waterfall

(a basic version)

Traditional, arr. Pete Showman

Musical score for 'Over the Waterfall' (basic version) in D major, 2/4 time. The score consists of four staves of music. The first staff begins with a repeat sign and a boxed 'A' above it. Chords are indicated above the notes: D, A, D, D, A, D. The second staff starts at measure 5 with chords D, A, D, C, followed by a first ending box with '1 G' and a second ending box with '2 G'. The third staff starts at measure 9 with a boxed 'B' above it and chords D, G, D, D, A, D. The fourth staff starts at measure 13 with chords D, G, D, D, A7, followed by a first ending box with '1 D' and a second ending box with '2 D (to repeat)'. The key signature has one sharp (F#) and the time signature is 2/4.

D major

♩ = 90

Over the Waterfall

(a fancier version)

Traditional, arr. Pete Showman

Musical score for 'Over the Waterfall' (fancier version) in D major, 2/4 time. The score consists of four staves of music. The first staff begins with a repeat sign and a boxed 'A' above it. Chords are indicated above the notes: D, A7, D, D, A7, D. The second staff starts at measure 5 with chords D, A7, D, C, followed by a first ending box with '1 G' and a second ending box with '2 G'. The third staff starts at measure 9 with a boxed 'B' above it and chords D, G, D, D, A7, D. The fourth staff starts at measure 13 with chords D, G, D, A7, followed by a first ending box with '1 D' and a second ending box with '2 D (to repeat)'. The key signature has one sharp (F#) and the time signature is 2/4.

Arr and typeset in ABC by Pete Showman. r4 2/8/2012

Santa Clara Valley Fiddlers Association
P.O. Box 2666
Cupertino, CA 95015-2666

**Next Jam: Sunday Nov. 1st, 1-5 pm
at Hoover Middle School**

SCVFA Jam on the first Sunday of each month.
Location: Hoover Middle School, 1635 Park Ave.,
San Jose. The school is at the corner of Naglee and
Park. Cafeteria parking is on the Naglee side.

**Damaged or Missing Issue? Call us,
or email to: [newsletter \[at\] scvfa.org](mailto:newsletter@scvfa.org)**

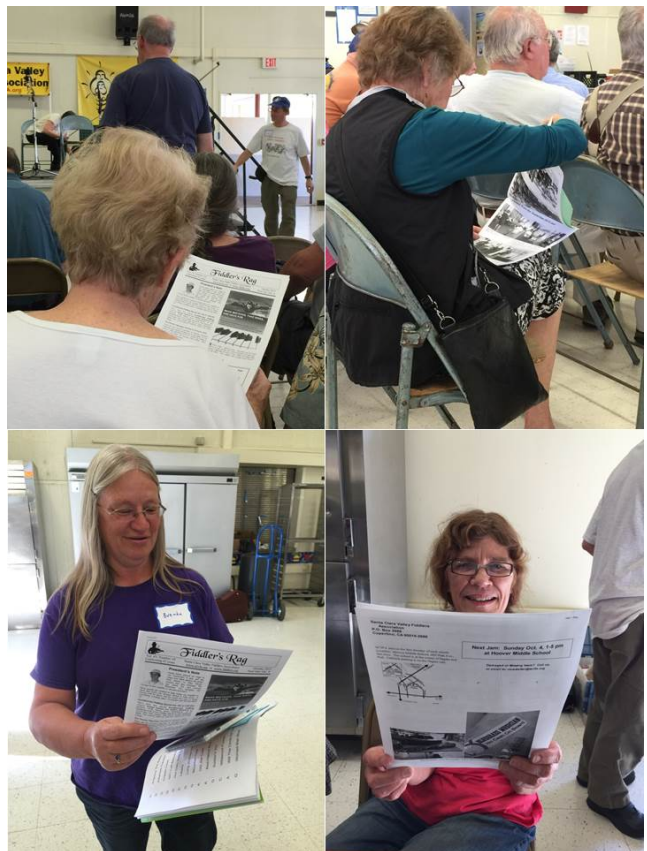
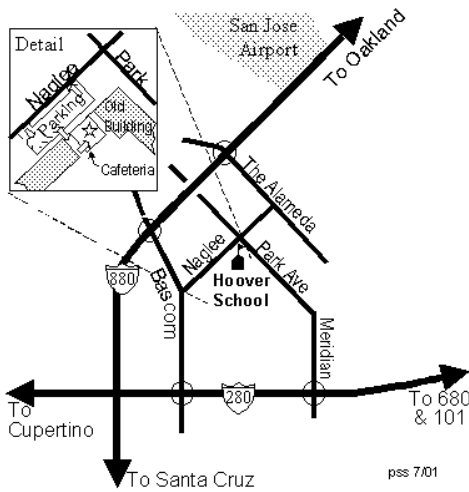

**Rag readers abound! Join the fun and give your
feedback at [newsletter \[at\] fiddlers.org](mailto:newsletter@fiddlers.org)**