



Fiddler's Rag

Vol. 44, Number 1
Celebrating 42 years

Santa Clara Valley Fiddlers Association
www.scvfa.org or www.fiddlers.org

January 2016
Next Jam: Jan. 3

President's Note



Happy New Year to everyone!

Our holiday potluck dinner was a great success due to the hard work of Cheri Palasek, Charlotte Prater and Lee Clarke.

Jean Avram once again led our popular slow jam and Dave Barton led our Tune Builder Circle. These programs and your participation contribute to our success.

February Membership Attendance IMPORTANT

It is very important that members come on February 7 because we need a quorum to elect two new trustees and approve changes to our bylaws. Superbowl weekend or not, we cannot postpone our election. The new Board of Trustees will appoint officers and a new President.

Invite-a-Friend Discount – January through March

From January through March 2016, the Board approved a \$5 door admission for everyone. We encourage you to invite a friend and save \$3 off the non-member rate.

Help at the Storage Locker (1 mile from the jam)

If you enjoy playing on stage, please signup at the desk to help take our storage locker supplies to the jam. Two people can bring all our equipment. It only takes 15 to 20 minutes to load and 10 minutes to drive.

Donate CDs for our Door Prize

Donate a CD you don't need for our door prize winners.

Share Your Photos

Share your photos and we will include your name if they are used in the Rag. Email them to newsletter editor Pat Tanti at [newsletter /at/ fiddlers.org](mailto:newsletter/at/fiddlers.org).

Amazon Buyers

Thanks to everyone who visited our website before purchasing their holiday gifts on Amazon. On the lower left side of our www.fiddlers.org website we have a link to Amazon. If you click on it to go to Amazon, we get a small commission if you make a purchase. It costs you nothing and it really helps us.



Lee Clarke and Gary Breitbard dancing to an open mike tune (Photo: Susan Goodis)



Charlotte Prater and Patti Bossert chatting by the buffet (Photo: Pete Showman)

In This Issue:

Page

| | |
|---|------|
| President's Message | 1 |
| Lost and Found | 2 |
| SCVFA Happenings | 3 |
| Candidates' Statements | 3 |
| Bylaws Changes..... | 4, 5 |
| Farewell to David E. Wunsch | 6 |
| Tune: Will the Circle be Unbroken | 7 |

- Richard Brooks

The Fiddler's Rag is published monthly by the Santa Clara Valley Fiddlers Association and is provided to members of the Association. The Santa Clara Valley Fiddlers Association (SCVFA), founded in 1973 in San Jose, California, is a nonprofit, volunteer-operated organization dedicated to the preservation, teaching, and enjoyment of traditional music. The first membership in a household includes the Fiddler's Rag; additional members sharing the newsletter are steeply discounted. To join, sign up at the jam or see www.fiddlers.org/join.

Officers and Chairs

| | | | |
|-----------------------|-------------------|----------------------------|------------------|
| President-Trustee ... | Richard J. Brooks | Newsletter Publisher .. | Charlotte Prater |
| Vice President | OPEN | Performances Contact .. | Dave Williams |
| Recording Secretary | Dinah Showman | Publicity | OPEN |
| Treasurer | Janet Johnston | Webmaster | Pete Showman |
| Membership Secretary | Pete Showman | Youth Programs Chair | OPEN |
| News Editor | Patrice Tanti | Youth Fiddle Contest | Pete Showman |

Trustees

| | | |
|----------------------|--------------------------|-----------------------|
| Seat 1: Pete Showman | Seat 3: George Bradshaw | Seat 5: Dave Williams |
| Seat 2: Élan Alford | Seat 4: Charlotte Prater | Seat 6: Susan Goodis |

To Contact the SCVFA:

Mail: P.O. Box 2666, Cupertino, CA 95015-2666
 Email to Richard Brooks: [president /at/ fiddlers.org](mailto:president@fiddlers.org)

Newsletter Submissions & Comments:

Email: [newsletter /at/ fiddlers.org](mailto:newsletter@fiddlers.org)

Website: www.scvfa.org or www.fiddlers.org
 Copyright 2016, Santa Clara Valley Fiddlers Association



Ellen Ehrenfried, George Bradshaw, Nick Hendershot, John Durbin, Wes Mitchell (Photo: Pete Showman)

Lost and Found

At the October jam: the rectangular green “blanket” from a fiddle case. If it’s yours, check with Pete or Dinah Showman, or any of the staff at the back table.

KAMIMOTO
 STRING INSTRUMENTS

“Fiddles
 for
 Every Style...”

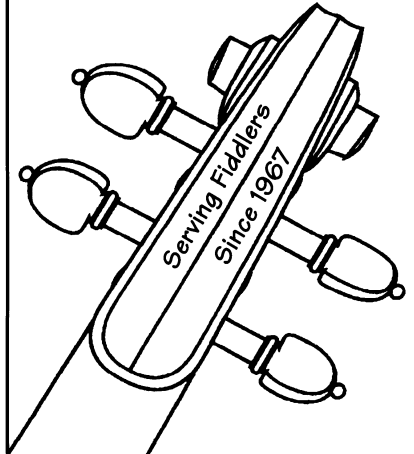

- New & Old Instruments
- Repairs & Restorations
- One-hour bow rehairing (by appt.)
- Rentals: Violin, Viola, Cello, Bass

Hours: Mon-Sat 10:00 - 5:30

[408] 298-8168
www.kamimotostrings.com

609 North Fourth Street
 San Jose, CA 95112

[800] 892-3199

Fax: [408] 298-8198

SCVFA Happenings

Trustee Election in February

As usual, we'll have our annual membership meeting at the February jam. The main items of business are the election of two trustees to three-year terms, and several Bylaws updates.

There are six elected trustees, with two elected each year so their terms overlap. The board of trustees has nominated two candidates for 2016-2019: **Bert Raphael** for Seat 3 and **Wes Mitchell** for Seat 4 (replacing George Bradshaw and Charlotte Prater, respectively, who have decided not to run again).

Member Nominations

The Bylaws also permit nominations by written petition signed by at least 3 members in good standing (dues paid up), submitted along with a written statement from the nominee (who must also be a member in good standing as of the election) agreeing to run. Such petitions must be submitted to the President (Richard Brooks) or Secretary (Dinah Showman) by 24 days before the election, i.e. by January 8, 2015. Nomination petitions may be mailed to the SCVFA mailing address on page 2, postmarked by the above date.

Candidates' Statements

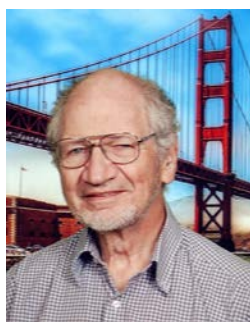

Bert Raphael

I was born in New York City and grew up in the Bronx. My mother was the neighborhood violin teacher, so I had lessons for a few years from about age three and played in my elementary-school orchestra. Then I hung up my violin and hardly touched it for more than sixty years. I enjoyed singing folk music in college and dabbled a bit with the banjo, accompanying myself while calling square dances for several New England college outing clubs.

I married my wife Anne in 1962, and we have resided in the Bay Area since I completed my Ph.D. degree in Mathematics at MIT, in 1964. My career included work as a computer scientist and manager at SRI International and Hewlett Packard.

Anne and I operated a travel agency in Mountain View. We have traveled throughout the world, and have

hosted many foreign visitors and youth exchange students. I spent 25 years volunteering with the National Ski Patrol, and taught first aid and CPR for the Silicon Valley Chapter of the Red Cross. I have been a Rotary member since 1990.

I enjoyed the sound of old time fiddling at local contra dances and started trying to play it. I love being a regular participant at the South Bay Old Time Jam, the monthly SCVFA sessions, and the occasional "community bands" at local contra dances. I would be delighted to help support these activities in any way I can.



Wes Mitchell

I started playing guitar in high school, switched to acoustic in college, then dropped it while in the throes of raising a child and career. In 2004, I decided I needed to be active again, but I wanted to try something different. One day, I walked into Gryphon, and a birth-year Gibson A-model mandolin just jumped into my hands. That worked for a while, but the itch to take up fiddle proved irresistible. I ascribe that to my mother's family's deep roots in West Virginia.

It's hard to say when I actually started "playing" fiddle. For many months, the screeching sound would travel through my jaw and make my teeth ache. I'm sure it wasn't real pleasant for others, either. I started going to workshops and camps, and was fortunate to have instructors such as Brad Leftwich, Bruce Greene, Mike Bryant, Erynn Marshall, and Eddie Bond. There would always be some key teaching that I was ready to learn, and I began to really enjoy the playing and camaraderie. I also finally learned to relax, which for me at least, makes me sound more musical.

I would like to see the SCVFA have more focus on workshops and mini-concerts. I enjoy giving the Tune Builder workshops, although if I continue, I really want to change the name to something else. I'd like to see more people get involved in leading directed jams, where folks could explore other genres. I think that would lend more continuity to our offerings. We have a real diversity of talent and interest in the group, we need to take more advantage of it. We also have a number of excellent fiddlers in the area that I would like to see give performances. Earl White comes to mind for old-time, there are many others.



Farewell to David E. Wunsch

By Grant and Larry Wunsch

It is with a heavy heart that we share with friends and family that our father, David E. Wunsch, passed away peacefully on November 17th.

Dave's wife passed away shortly thereafter.

Dave left us some instructions on what to do upon his passing. He asked that we send out the following notice to his friends and family.

This is your notification of the death of David E. Wunsch, formerly of San Jose, California; Orlando and Boynton Beach, Florida; Dallas, Texas; and Galesburg, Illinois. Mr. Wunsch died on 11/17/2015. This notice is being sent to you at his request, by one of his survivors. Please take whatever action seems appropriate.

Mr. Wunsch has suggested you should have either a shot of good scotch whiskey or a bottle of good beer. Tell your bartender that Mr. Wunsch is buying. Editorial comment: Dave's estate is not buying. Your bartender will need to go after Dave.

We hope to hold a joint memorial for our parents at a later date.

Dave Wunsch was an SCVFA member and regular jam attendee for 37 years, from 1976 to 2013.



Pete Showman, Sam Morocco, Dave Wunsch, Mike Schwartz, John Lytle
(2005 Photo: Richard Brooks)

Key: A Major
♩ = 75

Will the Circle Be Unbroken

A.P. Carter**



1. I was stand - ing by my win - dow, on a
 Chorus: Will the cir - - cle be un - - brok - en, by and
 2. Lord I told that un - der - - tak - - er, Un - der -
 3. I fol - lowed close be - - hind her, tried to
 4. I went home, My home was lone - ly, now my



cold and cloud - - y day, when I
 by, Lord, by and by. There's a
 ta - - ker please drive slow. For this
 hold up and be brave. But I
 mo - - ther she has gone. All my



saw that hearse come roll - - ing, for to
 bet - - ter home a - - wait - - ing, in the
 bo - - dy that you're tak - - ing,* Lord, I
 could not hide my sor - - row, when they
 broth - - ers, sist - - ers cry - - ing, what a

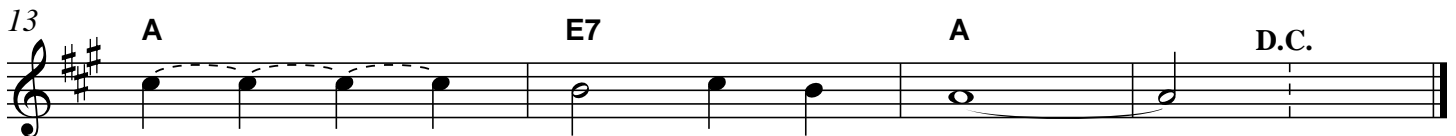

car - ry my moth - - er a - - way. (Chorus)
 sky, Lord, in the sky. (Chorus)
 hate to see her go (Chorus)
 laid her in the grave. (Chorus)
 home so sad and a - - lone. (Chorus)

* Or often "hauling" or "carrying"

**This version is generally credited to A.P. Carter of the Carter Family, but it was based in part on a 1907 hymn of the same name (words by Ada R. Habershon and music by Charles H. Gabriel). The chorus lyrics are similar and the melodies are vaguely related, but the verse lyrics are entirely different.

Arr. and typeset in ABC by Pete Showman 12/11/15 (rev 1).

Santa Clara Valley Fiddlers Association
P.O. Box 2666
Cupertino, CA 95015-2666

**Next Jam: Sunday Jan. 3rd, 1-5 pm
at Hoover Middle School**

SCVFA Jam on the first Sunday of each month.
Location: Hoover Middle School, 1635 Park Ave.,
San Jose. The school is at the corner of Naglee and
Park. Cafeteria parking is on the Naglee side.

**Damaged or Missing Issue? Call us,
or email to: newsletter@scvfa.org**

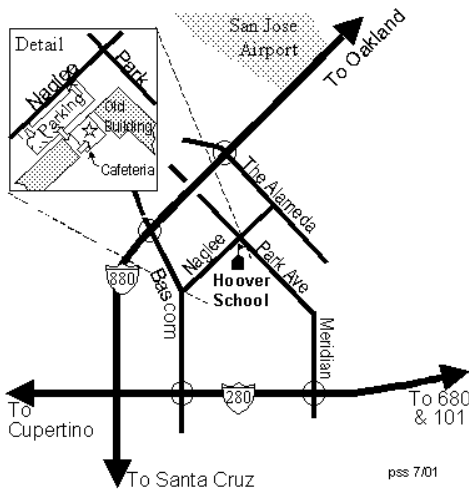

At the Cypress Senior Center 6-24-2011
Richard Brooks, John Durbin, Warren Campbell, Paul Clarke, and Dave Wunsch