



Fiddler's Rag

Vol. 41, Number 2
Celebrating 39 years

Santa Clara Valley Fiddlers Association
www.scvfa.org or www.fiddlers.org

February 2013
Next Jam: Feb. 3



President's Note

January 6 was a cold day and most folks stayed inside. It was easy getting folks to play on stage for listeners.

Jean Avram led our beginners circle (slow jam) outside in the cold. As usual, it was well attended and very popular.

Once-a-Year Help

If you drive, we could use your help once a year to carry some of the supplies from the storage locker to the jam at Hoover, an easy one-mile drive. You'll be assisting one or two others.

Contact Person for Playouts

We need someone to be the contact person when we are asked to perform in the community. The coordinator emails members to see who can participate and helps to select the music. Playouts are an important source of our revenue. It's not a lot of work, so help if you can.

Membership Election

February is when we have our annual membership meeting in which trustees are elected or reelected to three year terms. Charlotte Prater has agreed to continue as a trustee, and George Bradshaw has agreed to run. I will also give a summary of the state of our association.

Sam Morocco – part 2

My tribute to long-time SCVFA member Sam Morocco concludes with this issue. Sam was a trustee from February 2002 to February 2005. It was his idea to have a youth fiddle contest and our first was in 2002.

While Sam is comfortable playing at the back of the stage, he's at the front of my list when I want one of the best bass players around.

- Richard Brooks



Sam Morocco - Member Spotlight (Part 2)

[Continued from the January 2013 Fiddler's Rag]

By Richard Brooks

Sam and Donna married in 1958 and started their family. They have two daughters (Barbara and Lynne) and three grandchildren (Jenna, Christen, and Eric).

Donna's way of telling jokes was legendary. Her jokes were often risqué and always very funny. She always seemed to be the first to laugh. It was Donna who silk-screened the SCVFA T-shirts and sweatshirts with the SCVFA name and logo. Tragically, Donna died of cancer in 2003 and we lost a good friend.



Photo: Richard Brooks 11-3-2002

Ex-president Dick Barthelmess with Donna and Sam

While working as an office manager at Del Monte, Sam attended night school to earn a certificate in purchasing. For the next 15 years, he worked as a purchasing agent for the Kaiser Cement Company. While there, Sam made the largest purchase of his life – a locomotive from General Motors' Electric Division costing \$2.5 million. Although his superiors asked him to order it, they wouldn't sign an appropriation that large, so Sam did.

(Continued on page 4)

In This Issue:

Page

President's Message	1
Sam Morocco – Member Spotlight (part 2).....	1
Violin Lesson (humor)	2
SCVFA Happenings.....	3
(Sam Morocco, continued).....	4,5
December 2012 and January 2013 Jams.....	6
Tune: Cowboy Waltz.....	7

From Marin to Monterey, Tracy to Tiburon...
...we're in the heart of bluegrass country



THE NORTHERN CALIFORNIA
BLUEGRASS SOCIETY
www.ncbs.us

Since 1982 the Northern California Bluegrass Society has promoted bluegrass and old time music in the San Francisco Bay and Monterey Bay areas. This highly active club has nurtured the development of bands and venues. The NCBS hosts the Good Old Fashioned Bluegrass Festival each August, an event that solely features California bands. We sponsor festivals, concerts and jams all over the area. Members receive the Bluegrass By the Bay magazine each quarter. Please join us!

The Fiddler's Rag is published monthly by the Santa Clara Valley Fiddlers Association and is provided to members of the Association. The Santa Clara Valley Fiddlers Association (SCVFA), founded in 1973 in San Jose, California, is a nonprofit, volunteer-operated organization dedicated to the preservation, teaching, and enjoyment of traditional music. The first membership in a household includes the Fiddler's Rag; additional members sharing the newsletter are steeply discounted. To join, sign up at the jam or see www.fiddlers.org/join.

Officers and Chairs

President-Trustee Richard J. Brooks
 Vice President OPEN
 Treasurer Janet Johnston
 Membership Secretary Pete Showman
 Recording Secretary Dinah Showman
 Newsletter Editor OPEN (*Pete Showman, acting*)
 Newsletter Publisher Charlotte Prater
 Payout Coordinator OPEN
 Publicity Tom Clausen
 Webmaster Pete Showman
 Youth Activity Coordinator Mary Kennedy
 Youth Fiddle Contest Chair, 2012 Jaclyn Chiew

Trustees

Seat 1: Pete Showman Seat 2: Barbara Rosner
 Seat 3: Paul Clarke Seat 4: Charlotte Prater
 Seat 5: Dave Williams Seat 6: Tom Clausen

To Contact the SCVFA:

Mail: P.O. Box 2666, Cupertino, CA 95015-2666
 Email: president@fiddlers.org Phone: (650) 328-3939

Newsletter Submissions & Comments:

Email: newsletter@fiddlers.org
 Website: www.scvfa.org or www.fiddlers.org
 Copyright 2012, Santa Clara Valley Fiddlers Association

Violin Practice



Little Harold was practicing the violin in the living room while his father was trying to read in the den. The family dog was lying in the den, and as the screeching sounds of little Harold's violin reached his ears, he began to howl loudly.

The father listened to the dog and the violin as long as he could. Then he jumped up, slammed his paper to the floor and yelled above the noise, "For Pete's sake, can't you play something the dog doesn't know?!"



Richard Brooks photo

Arthur Kee, Sam Morocco, Anita Marley and Jim True entertain at the January jam.

SCVFA Happenings

Pete Showman

Annual Meeting & Trustee Election

Reminder: the SCVFA annual member meeting and election will be held beginning at 3 pm during the February jam. Anyone is welcome to attend, but only SCVFA members in good standing (i.e. dues paid up) may vote.

We will elect two trustees to three year terms. There are two nominees: incumbent **Charlotte Prater**, and **George Bradshaw**. See the January edition of the Fiddler's Rag for candidate statements.

After the election President Richard Brooks will give us an update on the state of the association, and provide an opportunity for questions and suggestions.

Barbara Rosner Appointed Trustee

At its January 20 meeting the SCVFA board of trustees appointed member **Barbara Rosner** to fill out the remaining year of Gorden Gibson's term, following his resignation from the board.

Barbara, thanks for being willing to help lead the association!

More Help Still Needed

Not to sound like a broken record or anything, but in addition to the trustees, we really need more help to keep SCVFA operating smoothly.

Our current needs include:

- Newsletter editor for the Fiddler's Rag.
- One or two people to help organize "playouts," our fund-raising performances. Paul Clarke is retiring from the position in February after five years.
- Recording Secretary or Treasurer
- Vice President
- People to help in various ways at the monthly jam: get open mike signups, help transport the PA system to and from the jam (once a year or so), help set up and take down the PA system, offer to help at the back desk to give the desk workers a break.

Please contact any trustee or officer if you can help in any way.

Trustee Meeting Highlights

The SCVFA Trustees met on January 20, 2013 and took the following actions

- Appointed Barbara Rosner to serve in the trustee position (seat 2) vacated by Gorden Gibson for the one year remaining in the term.
- Thanked Paul Clarke for his many contributions to SCVFA as trustee, payout coordinator and president.
- Considered how to find volunteers for coordinating payouts, picking up equipment for jams, and other tasks.
- Planned agenda for the annual association meeting and a special trustee meeting at the February jam (trustees meet following the association meeting to appoint officers for the next year).
- Made plans for a KidFiddle workshop at the March jam, to be taught by Luke Abbott.
- Discussed objectives of our youth program and whether we are meeting them. Considered how to structure and promote our KidFiddle classes to be most effective, and considered other ways of encouraging youth to participate in SCVFA.
- Set March 17 as the next tentative trustee meeting date.

Dinah Showman, Secretary

Trustee meetings are open to all SCVFA members. They're usually held on 3rd Sundays of odd-numbered months (subject to change depending on conflicts). If you'd like to attend a meeting, contact Richard Brooks: President@fiddlers.org.

California State Fiddle Contest Mar. 14

The annual California State Championship fiddle contest will be held in Oroville, California on March 14-16, 2013. The contest is put on by the California State Old Time Fiddlers Association (CSOTFA), and is the state contest sanctioned by the National Old Time Fiddlers Association (NOTFA).

Unfortunately their new address, www.thecsotfa.com seems to be out of order, and their previous address, www.csotfa.net, is no longer valid.

Alternatively, some of the districts' web pages may have contest information. Try www.csotfa.org (District 6), www.calfiddlers.com (District 8, which seems to have a pretty good site), or www.csotfa9.org (the Bay Area's District 9).

(Sam Morocco – Member Spotlight, cont. from p.1)

Sam started playing bluegrass music during the late 1950's and early 1960s. Pizza parlors were hosts to bands just as they are today. In 1974, the Last Train Home bluegrass band was formed with members Sam Morocco (bass), Chuck Adams (guitar, lead singer), Jack Steitz (banjo, harmonica), Carl Ketchum (mandolin, backup fiddle), Gene Marshack (fiddle), Stan Ketchum (fiddler before Gene), Karen Steitz, (Jack's daughter).

The band got its name from a Woody Guthrie song. They were very popular with the local square dancers and their photo was even on the front page of the June 1980 issue of The Prompter Magazine, devoted to square and round dancing.

Solution For A Limited Set List

A pizza parlor owner invited them to play two sets in exchange for free pizza, but they were reluctant to accept because they only knew 12 songs. The owner provided the solution: "Play songs 1 through 12. Then start with number 10 and go back. By the time you get to number 1 again, the crowd will have changed and you can start over." It worked!



Richard Brooks photo

Top: Sam playing fiddle, Nov. 2001
Right: With the Peninsula Banjo Band, May 2010



Charlotte Prater photo

Sam and Richard Brooks, February 2010



Sam (bass), Jack Steitz (banjo), Chuck Adams (guitar), and Carl Ketchum (fiddle)

BMI Halts Gigs

The Last Train Home was very popular and drew big crowds to their pizza parlor gig. But it was cut short because the owner could not afford to keep them. It wasn't the cost of the free pizza. It was because BMI, the music publisher, insisted that the owner pay them \$2,000 for the band to sing copyrighted songs that it owned the rights to! It didn't matter that the band said they were doing public-domain songs from the Alan Lomax song book. The owner had to let the band go. That still happens in small clubs today – in 2013.

Sam's Performances and Recordings

Sam has performed with many now famous SCVFA members over the decades. They include John Stout, John Lytle, Lance Gordon, Art Deems, Howard Jackson, Frosty Robinson, Bill Carlson, and others at locations too numerous for Sam to remember. Many of these folks can be heard on the historic CDs available at the back table at every SCVFA jam.

Sam was in the Great American Dance Band (a big band). For the last 18 years, he's been in the Silicon Gulch Jazz Band (traditional jazz). They perform at the Swinging Door in San Mateo on Tuesday nights.

Sam's bass playing can be heard on many recordings: The Silicon Gulch Jazz Band (Dixieland), "Showboat Shuffle" (South Bay Stompers), "That Charlie Sound" and "More, More, More" (Penninsula Banjo Band), "Bluegrass Country" (Tom Mitchell), "Antique Junk Fiddler" (Art Deems), and on recordings done in studios.

No Idle Time in Retirement

Before Sam retired in 1998, he made a list of the things he wanted to do during retirement. First on the list was learning how to repair computers, so he took a class in that. The instructor liked him so much he asked him to continue as his assistant for three years!

Next on Sam's list was being a camera man. His motive was to see the Giants games for free, but that never happened. Sam took a local course offered through San Jose State University at Comcast Studios. He volunteered there as a cameraman for eight years. On Tuesdays he worked on a cooking show sponsored by Sam's BBQ restaurant, and Wednesdays on the Guitar Showcase. He worked on educational programs with local celebrities like Belva Davis. Sam's BBQ is the same San Jose restaurant that currently hosts bluegrass music on Tuesday and Wednesday nights.



Stewart Yarbrough, Sam, John Stout, and John Lytle perform at the Red Barn in Alameda.

Next was Sam's love of golf and bowling. He is the "golf marshal" at the Santa Teresa Golf Course on Fridays and Saturdays. In exchange for riding around in a golf cart to keep people moving from hole to hole, he gets to play for free. He is also the secretary of a senior bowling league and goes bowling every Wednesday.

Current and Future Activities

Sam is the most in-demand musician at the SCVFA jams and appears on stage with his bass or tenor guitar every time he attends. He continues to actively play music and currently plays with the South Bay Jazz Club and the Monterey Hot Jazz Club.

Sam's future goals are to "keep playing music as long as I can," "keep playing golf as long as I can," and "keep loving people 'til I die."



Arthur Kee, Anita Marley, Evelyn McCuiston, Sam, Bill Whitfield, Norio Kawato 2-7-2010

R. Brooks photo

December 2012 & January 2013 Jams

All photos by Richard Brooks



New trustee Barbara Rosner (bass), Bill Whitfield (fiddle) and John Durbin (guitar) entertain at the January 2013 jam.

Dinah and Pete Showman at the December Potluck; Pete is showing off the SCVFA T-shirt designed by Richard Brooks.



Jena Rauti and Gary Breitbard dance to the Nancy Solomon Potluck Band's post-dinner entertainment in December.

KAMIMOTO STRING INSTRUMENTS

“Fiddles
for
Every Style...”

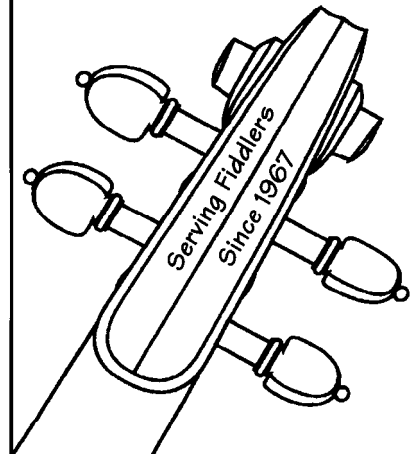

- New & Old Instruments
- Repairs & Restorations
- One-hour bow rehairing (by appt.)
- Rentals: Violin, Viola, Cello, Bass

Hours: Mon-Sat 10:00 - 5:30

[408] 298-8168
www.kamimotostrings.com

609 North Fourth Street
San Jose, CA 95112

[800] 892-3199

Fax: [408] 298-8198

Cowboy Waltz

Traditional?

Key: D

♩ = 140

From Woodie Guthrie

The musical score for "Cowboy Waltz" is written in 3/4 time with a key signature of one sharp (F#). The tempo is marked as ♩ = 140. The score is divided into six systems, each starting with a measure number. Chords are indicated above the staff. A repeat sign is present at the beginning of the first system. The final system includes first and second endings.

System 1 (measures 1-8): Chords: A, D, (F#m)*, D**, G, D. Measure 1 contains a repeat sign.

System 2 (measures 9-16): Chords: D, (F#m)*, D**, A, A7.

System 3 (measures 17-24): Chords: A', D, (F#m)*, D**, G, D, D (with a triplet of eighth notes).

System 4 (measures 25-32): Chords: G, A, D, G, D, A7, D.

System 5 (measures 33-40): Chords: B, D, G, A, A7, D.

System 6 (measures 41-48): Chords: D, G, A, A7, D. The system concludes with first and second endings.

Notes: * Chord players should agree whether to do the optional F#m's. The melody chord is OK either way.

** You could play a 1-measure Bm here -- but then the low note in the melody chord must be a more-awkward 'B'.

Typeset and transcribed 3/21/2012 by Pete Showman, from a Dave Fox and Will Branch video on YouTube: www.youtube.com/watch?v=BiDzsZpz-YE which in turn was based on a recording by the New Lost City Ramblers. Woodie Guthrie also recorded it, playing fiddle(!) on his Buffalo Skinners album; see www.youtube.com/watch?v=oJ9wexPhUAI. Revised (r4) 1/22/13.

Santa Clara Valley Fiddlers Association
P.O. Box 2666
Cupertino, CA 95015-2666

**Next Jam: Sunday Feb. 3, 1-5 pm
at Hoover Middle School
Annual Meeting and Election at 3pm**

SCVFA Jam on the first Sunday of each month.
Location: Hoover Middle School, 1635 Park Ave.,
San Jose. The school is at the corner of Naglee and
Park. Cafeteria parking is on the Naglee side.

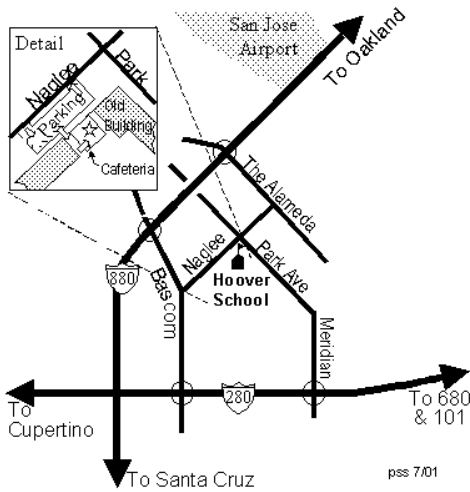

**Damaged or Missing Issue? Call us,
or email to: newsletter@scvfa.org**



Richard Brooks photo

Triple Fiddles at the January 2013 Jam L-R: Arthur Kee, Sam Morocco, John Sellers, Anita Marley and Chip Curry