



# Fiddler's Rag

Vol. 45, Number 4  
Celebrating 44 years

Santa Clara Valley Fiddlers Association  
[www.scvfa.org](http://www.scvfa.org) or [www.fiddlers.org](http://www.fiddlers.org)

April 2017  
Next Jam: Apr. 2

## President's Note



Neither snow nor rain nor heat nor gloom of night stays these musicians from their obsession to jam. This was so true for the March jam when the Bay area was hit with torrential downpours and hailstorms. As good fortune would have it, only a drizzle passed over Hoover School.

Wes Mitchell taught two really nice tunes, 'Devil Ate the Groundhog' and 'Coal Harbor Bend', at the Tune Builder Circle. Gary Breitbart taught 3 tunes, 'Shoes & Stockings', 'Shoo Fly' and 'Say Darling Say' for the KidFiddle Workshop. Both groups took the stage to share the music. Thanks to both Wes and Gary for passing on the music tradition.

Thanks to Élan Alford, Jam Manager, Topher Heath, Slow Jam leader, and Dinah Showman & Charlotte Prater for snacks and admission desk. Many thanks to all the folks who pitch in to make this jam happen. Many hands make small work.

We are currently seeking two people to chair these positions: **publicity and youth programming**. The time commitment is small, but the reward will be great.

**Erik Hoffman** will lead another **KidFiddle** in April. He is certain to teach and entertain our young fiddlers.

**John Gregorin** will lead the April **Tune Builder Circle**. John will also host an '**original tunes**' session; he asks that people bring sheet music for their original tunes so others may play songs. Come learn some new music to build your repertoire.

Jam times: 1:00 - 5:00pm  
Slow Jam: 1:30 - 2:30 led by Topher Heath  
Original Tunes: 1:00 - 2:00 led by John Gregorin.  
Tune Builder: 2:00 - 3:00 led by John Gregorin  
KidFiddle: 2:00 - 3:00

-----  
There are scores of Easy Ways to keep SCVFA healthy with minimal time expenditure:

- Come and jam with us every month.
- Play on stage for the SCVFA open mic.
- Take a few SCVFA business cards to hand out to fellow musicians.
- Invite non-musician friends to be our audience and part of our community.
- Offer assistance 1-2 times a year to transport sound equipment from the storage locker.
- Amazon purchases - initiate from SCVFA home page to give a small commission to SCVFA.
- Photographers ... or wanna be's - share your talent by photographing memorable times at SCVFA events - send to Pat Tanti at newsletter [at] fiddlers.org
- Pass on performance inquiries to Dave Williams at performances [at] fiddlers.org
- Attend a board meeting - all SCVFA members are welcome - **Tuesday March 28th at the home of Susan Goodis** -- potluck dinner immediately preceding.

It takes a village to keep SCVFA running smoothly. Let us all do our part.

*Susan Goodis*



Show your pride in SCVFA, get your wearable!  
Email [sgoodis \[at\] gmail](mailto:sgoodis@gmail.com) for information

In This Issue:	Page
President's Message .....	1
New Music Terms (Music Humor by Anonymous)...	2
SCVFA Happenings.....	3
March photos .....	4,5
Flyer: KidFiddle Workshop with Erik Hoffman .....	6
Tune: "Johnny, Johnny, Don't Get Drunk" .....	7
Tune: "Step Around Johnny".....	7

The Fiddler's Rag is published monthly by the Santa Clara Valley Fiddlers Association and is provided to members of the Association. The Santa Clara Valley Fiddlers Association (SCVFA), founded in 1973 in San Jose, California, is a nonprofit, volunteer-operated organization dedicated to the preservation, teaching, and enjoyment of traditional music. The first membership in a household includes the Fiddler's Rag; additional members sharing the newsletter are steeply discounted. To join, sign up at the jam or see [www.fiddlers.org/join](http://www.fiddlers.org/join).

### Officers and Chairs

President-Trustee .....	Susan Goodis	Newsletter Publisher ..	Charlotte Prater
Vice President .....	Élan Alford	Performances Contact ..	Dave Williams
Recording Secretary ....	Anne Raphael	Publicity .....	OPEN
Treasurer .....	Dinah Showman	Webmaster .....	Pete Showman
Membership Secretary	Pete Showman	Youth Programs Chair .....	OPEN
News Editor .....	Patrice Tanti		

### Trustees

Seat 1: Pete Showman	Seat 3: Bert Raphael	Seat 5: Dave Williams
Seat 2: Élan Alford	Seat 4: Wes Mitchell	Seat 6: Cindy Dinga

### To Contact the SCVFA:

Mail: P.O. Box 2666, Cupertino, CA 95015-2666

Email to Susan Goodis: [president \[at\] fiddlers.org](mailto:president@fiddlers.org)

Newsletter Submissions & Comments: [newsletter \[at\] fiddlers.org](mailto:newsletter@fiddlers.org)

Address changes: [membership \[at\] fiddlers.org](mailto:membership@fiddlers.org)

Website: [www.scvfa.org](http://www.scvfa.org) or [www.fiddlers.org](http://www.fiddlers.org)

Copyright 2017, Santa Clara Valley Fiddlers Association

# KAMIMOTO

## STRING INSTRUMENTS

“Fiddles  
for  
Every Style...”

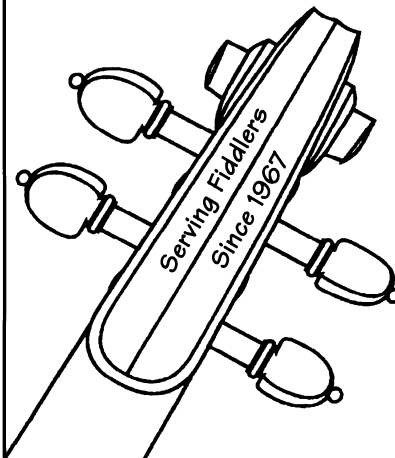

- New & Old Instruments
- Repairs & Restorations
- One-hour bow rehairing (by appt.)
- Rentals: Violin, Viola, Cello, Bass

Hours: Mon-Sat 10:00 - 5:30

**[408] 298-8168**

[www.kamimotostrings.com](http://www.kamimotostrings.com)

609 North Fourth Street  
San Jose, CA 95112

**[800] 892-3199**

Fax: **[408] 298-8198**

### New Music Terms

Music Humor by Anonymous

**ALLEREGRETTO:** When you're 16 measures into the piece and suddenly realize you set too fast a tempo.

**ANGUS DEI:** To play with a divinely beefy tone.

**A PATELLA:** Accompanied by knee-slapping.

**APOLOGGIATURA:** A composition that you regret playing.

**APPROXIMATURA:** A series of notes not intended by the composer, yet played with an "I meant to do that" attitude.

**APPROXIMENTO:** A musical entrance that is somewhere in the vicinity of the correct pitch.

**DILL PICCOLINI:** An exceedingly small wind instrument that plays only sour notes.

**FERMANTRA:** A note held over and over and over and ...

**FIDDLER CRABS:** Grumpy string players.

**FLUTE FLIES:** Those tiny insects that bother musicians on outdoor gigs.

**FRUGALHORN:** a sensible and inexpensive brass instrument.

**GAUL BLATTER:** A French horn player.

**GREGORIAN CHAMP:** The title bestowed upon the monk who can hold a note the longest.

**PLACEBO DOMINGO:** A faux tenor.

**SPRITZICATO:** An indication to string instruments to produce a bright and bubbly sound.

**TEMPO TANTRUM:** What an elementary school orchestra is having when it's not following the conductor.

# SCVFA Happenings

## SCVFA Slow Jam Active song list

Thank you all for participating in the slow jam. The slow jam is for beginners who want to participate in a slow-paced jam (60-90 BPM). To participate, you should be able to tune your instrument, play chords at a steady pace, and (optionally) work up melodies / leads. We keep things at an easy pace and we often play breaks together (old time style) even on non-fiddle tunes. This makes it possible for you to join the jam wherever you are at in your development as a musician. So, come join us!

All the tunes we have played so far are fair game even if they are not on the active list. We can revisit tunes especially at the end when we have gone through the active list.

Angeline the Baker (D)	Red-Haired Boy (A)
Arkansas Traveler (D)	Red Wing (G)
Girl I Left Behind Me (G)	Soldier's Joy (D)
Jaybird (D)	Squirrel Hunters (A)
June Apple (A)	St. Anne's Reel (D)
Liberty (D)	Swallowtail Jig (E)
Mississippi Sawyer (D)	Whiskey Before Breakfast (D)
Over the Waterfall (D)	Wildwood Flower (C)

Check here first for songs: [scvfa.org/tunes/](http://scvfa.org/tunes/)

If you have trouble finding a song, feel free to contact me for ideas.

Note: To add or remove yourself from the email list for the Slow Jam, send a request to [topher.heath \[at\] yahoo.com](mailto:topher.heath@yahoo.com).

*Topher Heath*

## April Events

4/1 Sunnyvale Evening of Cultural Arts presents "James Garner's Tribute to Johnny Cash".

4/2 Music Jam and Open Mike at Hoover School, plus a KidFiddle workshop with Erik Hoffman.

4/22 Redwood Bluegrass Associates presents "Grand Finale Concert" (their very last concert after 25 years).

## March Board Meeting

The next board meeting will be Tuesday March 28th. Members are encouraged to attend. Please contact any board member for specifics.

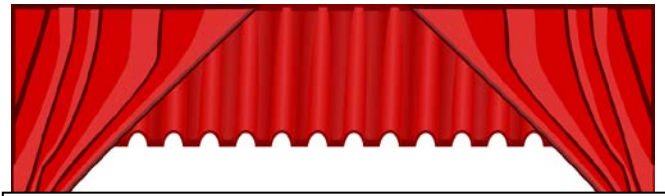

Share any performance opportunities with Dave Williams at [performances \[at\] fiddlers.org](mailto:performances@fiddlers.org) and let him know if you would like to be included as a performer.

## SCVFA now has a Facebook Page

Look for: "Santa Clara Fiddlers Association SCVFA". Share with your friends and invite new friends to get to know our music community. Share our events on your own page. You never know which of your friends may join SCVFA next month. Posts are encouraged, but limit the content to that which is directly related to SCVFA.



It is important that each of our members continues to talk about SCVFA and shares our enthusiasm with fellow musicians, family, and friends. Take a few business cards and share them when the opportunity presents itself.

## March 2017 Photos



SCVFA members Patti Bossert, Cindy Dinga and Susan Goodis rehearsing for the Monterey Monster Band at Lovers Point in Pacific Grove.  
(Photo: Susan Goodis)



March SCVFA Jam: Bluegrassers jamming... complete with the washtub bass.  
(Photo: Susan Goodis)

## March 2017 Photos (Cont'd)



Bluegrass on a chilly day.  
(Photo: Pete Showman)



Tune Builder ... we learned 'Devil Ate the Groundhog' and 'Coal Harbor Bend'. Thanks Wes!  
(Photo: Susan Goodis)



Tune Builder group performing: Wes Mitchell, Susan Goodis, Ann Whitesell and Élan Alford.  
(Photo: Pete Showman)

# Santa Clara Valley Fiddlers Association

## Sunday April 2, 2017

### KidFiddle Workshop



**Instructor: Erik Hoffman**

**KidFiddle Workshop:** 2:00-3:00 pm

*KidFiddle* workshops are intended for advanced-beginner to intermediate fiddlers, ages 17 and under.

Tuition is only \$5, and youth admission to the jam is free as always. You can sign up at the event, but we'd appreciate hearing from you in advance (at [kidfiddle /at/ fiddlers.org](http://kidfiddle.fiddlers.org)) if you know a young fiddler who would like to participate. After the *KidFiddle* workshop we'll ask the students to perform on stage with Erik. Come to hear what the students have learned, and stay to jam with Erik.

Erik has been a musician and dance caller for over 30 years. Traveling all over the state, Erik has become well known from Arcata to San Diego, and from Carson City, Nevada, to the Bay Area. He has also toured the United States extensively, on both coasts, and in between. He has been staff at a number of festivals in California, New York, New Mexico, and Washington state. Erik has been in numerous bands: The OpporTunists, Erik Thor and Hands Four, 3 O'Clock Shadow, and he currently plays in The Rosin Doctors.

**April 2, 2017 at Hoover Middle School**  
**Naglee Ave at Park Ave San Jose**

Jam 1-5pm

Adult Admission \$6.00 members

\$8.00 non-members

Free Admission for youths 17 and under

KidFiddle Workshop 2:00 - 3:00

for youths 17 and under \$5.00 Tuition

Sign up at [KidFiddle \[at\] Fiddlers.org](http://KidFiddle[at]Fiddlers.org)

Open Mic before and after the concert.

More details & general SCVFA information

[www.Fiddlers.org](http://www.Fiddlers.org)

or call Susan Goodis at 650-336-5561

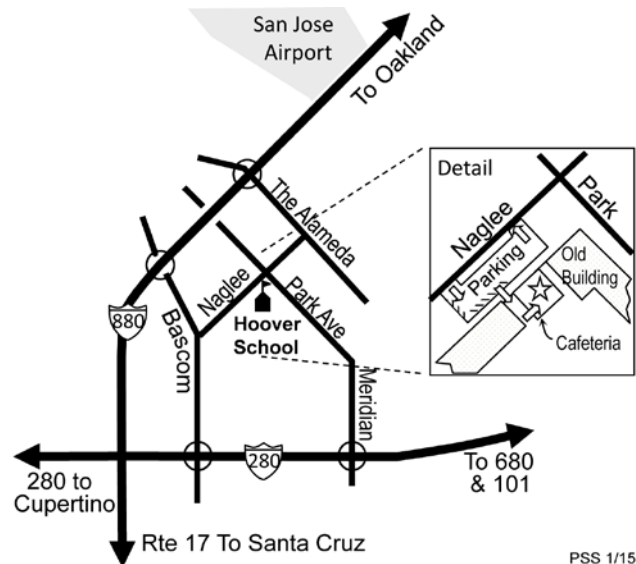

You can hear MIDI renderings of the tunes at [www.showman.org/tunes](http://www.showman.org/tunes)  
These tunes aren't related as far as I know -- but they could be!

Key: D

♩ = 90

# Johnny, Johnny, Don't Get Drunk

Traditional

(aka Johnny, Johnny, Don't Come Home Drunk)

Arr. Pete Showman

Musical score for 'Johnny, Johnny, Don't Get Drunk' in D major, 4/4 time. The score consists of four staves of music. The first staff (measures 1-4) is marked with a boxed 'A' and contains chords D, G, and A. The second staff (measures 5-8) contains chords D, G, A, and D. The third staff (measures 9-12) is marked with a boxed 'B' and contains chords D, G, and A, with the instruction '(or same as prev. meas.)' above measures 10-11. The fourth staff (measures 13-16) contains chords D, G, D, G, A, and D. The key signature has two sharps (F# and C#).

Arr. Pete Showman; rev. 3 2/1/2013.

A mix of the ways I usually play it. See the Portland Collection for some variations.

Key: D

♩ = 90

# Step Around Johnny

Traditional

Arr. Pete Showman

Musical score for 'Step Around Johnny' in D major, 4/4 time. The score consists of four staves of music. The first staff (measures 1-4) is marked with a boxed 'A' and contains chords D, G, D, and a triplet of eighth notes. The second staff (measures 5-8) contains chords D, G, D, and A, followed by two first endings marked '1 D' and '2 D'. The third staff (measures 9-12) is marked with a boxed 'B' and contains chords D, G, and D. The fourth staff (measures 13-16) contains chords D, A, and two first endings marked '1 D' and '2 D'. The key signature has two sharps (F# and C#).

Arr. and typeset in ABC by Pete Showman, 6/30/2014 (rev. 1).

Sometimes for fun we play it with *Johnny, Johnny, Don't Get Drunk* (also in D).

Santa Clara Valley Fiddlers Association  
P.O. Box 2666  
Cupertino, CA 95015-2666



SCVFA Jam on the first Sunday of each month.  
Location: Hoover Middle School, 1635 Park Ave.,  
San Jose. The school is at the corner of Naglee and  
Park. Cafeteria parking is on the Naglee side.

**Next Jam and KidFiddle  
Workshop: Sunday Apr. 2<sup>nd</sup>  
1-5 pm at Hoover.**

**Damaged or Missing Issue? Call us,  
or email to: [newsletter \[at\] scvfa.org](mailto:newsletter@scvfa.org)**

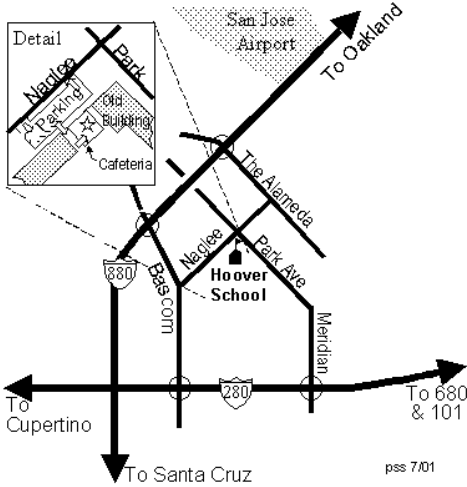

MaryAnn and Tom Clausen at the March 2017 Jam  
(Photo: Susan Goodis)